

WasteMaid[®] PRO

659 FOOD WASTE DISPOSER



1/2 HORSEPOWER

BIO SHIELD DISPOSER SERIES

Easy and Fast to Install

Waste Maid PRO disposers feature Speed Master Mounting, an exclusive system that provides fast and economical installation.

Permanent Magnet Motors

Waste Maid PRO motors offer maximum torque instantly with the power to cut through potential jams.

Removable Splash Guard

All Waste Maid PRO continuous feed models have a removable splash guard, ideal for easy cleaning and replacement.



BIO SHIELD
(Antimicrobial)
for **ODOR PROTECTION!**
Disposers are treated with an antimicrobial agent molded inside providing protection against odor causing bacteria growth.



The TORQUE MASTER
Grinding System is a combination of computer designed and balanced components working in unison to provide superior torque grind speed and long system life.

HORSEPOWER	1/2 HP
MOTOR SPEED RPM	2600 RPM
VOLTAGE	120v
AMPS	4.5
CYCLES	60
BEARINGS	Permanently Lubricated, Sleeve Type
MOTOR TYPE	Permanent Magnet
SPLASH GUARD	Removable
GRIND RING	Cold Rolled Steel
SWIVEL IMPELLERS	Stamped Stainless Steel
BALANCED TURNTABLE	Cold Rolled Steel
BALANCED ARMATURE SHAFT	Yes
HOPPER	Corrosion Proof
DRAIN HOUSING	Corrosion Proof
APPLIANCE PROTECTOR	Manual Reset
SINK FLANGE CAP	Stainless Steel
MOUNT ASSEMBLY	Speed Master-Threaded
SOUND SHELL	Partial
ATTACHED POWER CORD	Yes
DISHWASHER CONNECTION	Yes
UNIT WEIGHT	9.6 lb
INDIVIDUAL SHIPPING WEIGHT	10 lb
LIFETIME CORROSION GUARANTEE	No
WARRANTY	2 Years

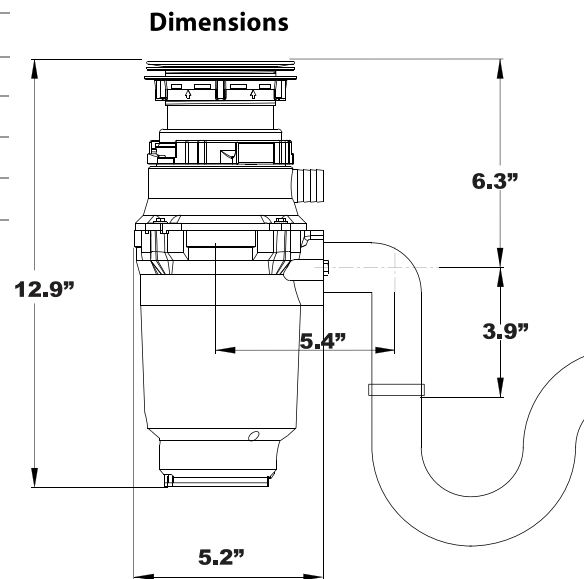

Joneca Corporation

4332 E. La Palma Avenue, Anaheim, California 92807
Telephone: 714.993.5997 Fax: 714.993.2126 Toll Free 1-888-8Joneca
Website: www.Joneca.com Email: ContactUs@Joneca.com

©2017 Joneca Corporation, All Rights Reserved.
55-659-171